

18534-1

Notice!

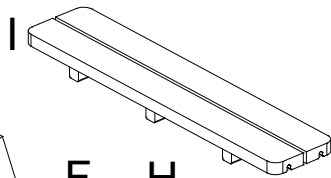

x4

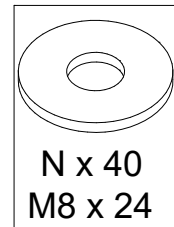
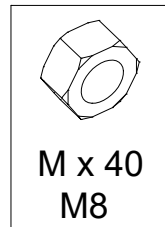
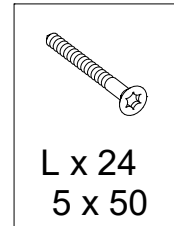
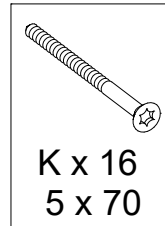
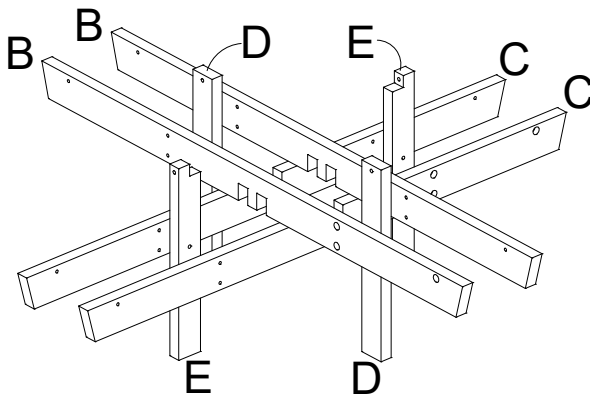
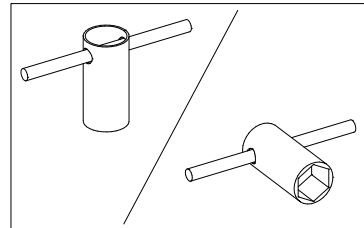
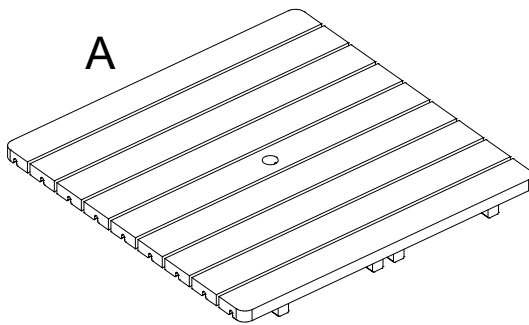
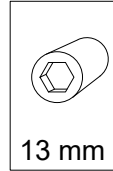
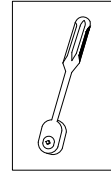
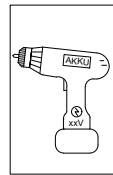
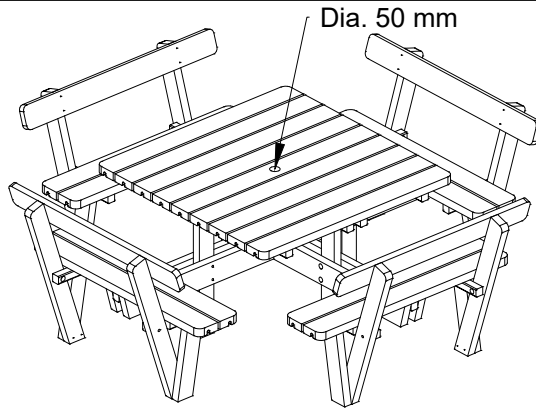
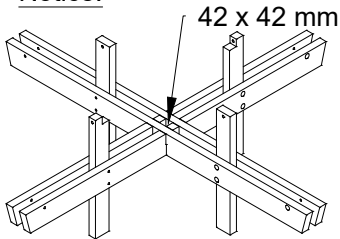
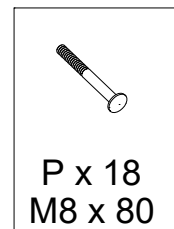
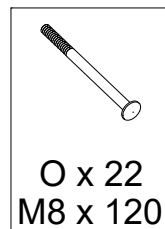
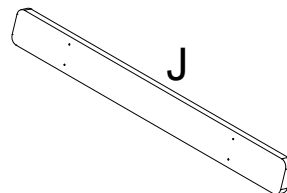
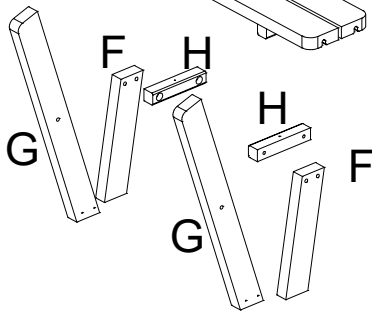

1

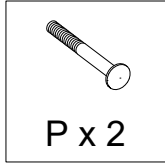
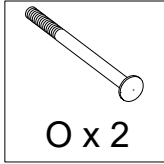
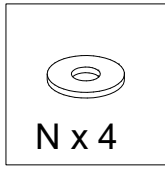
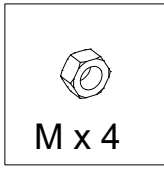

Møtrikker (M) strammes til, når hele bænken er samlet.

Erst nach der kompletten Montage alle Schraubenmutter (M) fest anziehen.

Nuts (M) tightened when entire bench is assembled

Écrous (M) serrés quand le banc est assemblé.

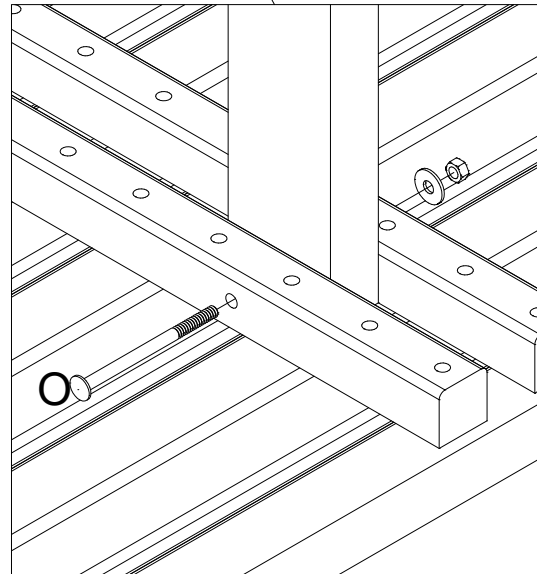
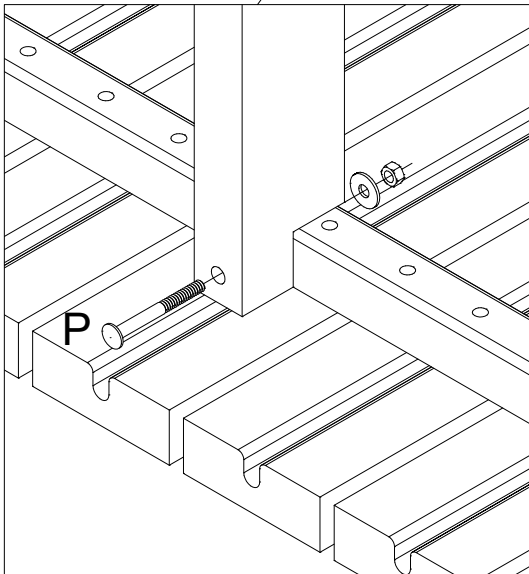
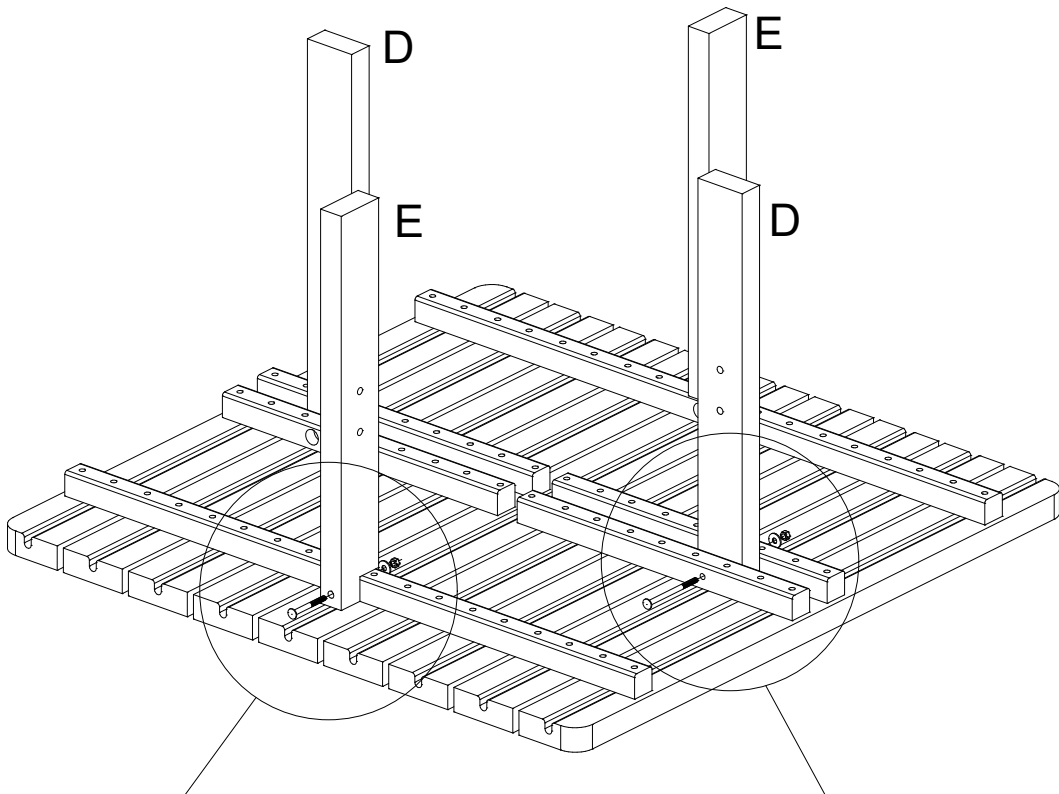

2

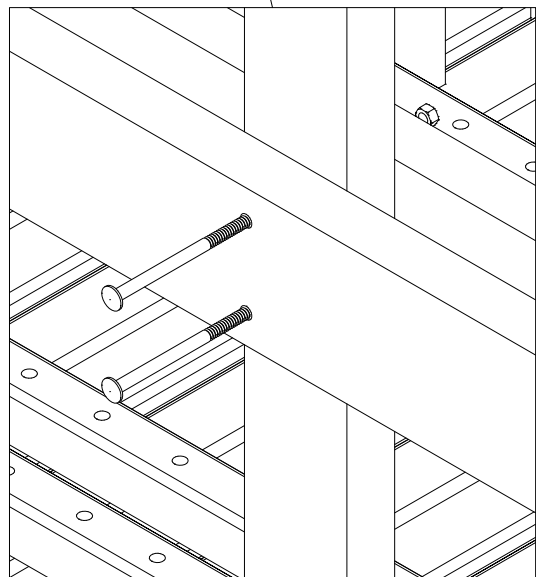
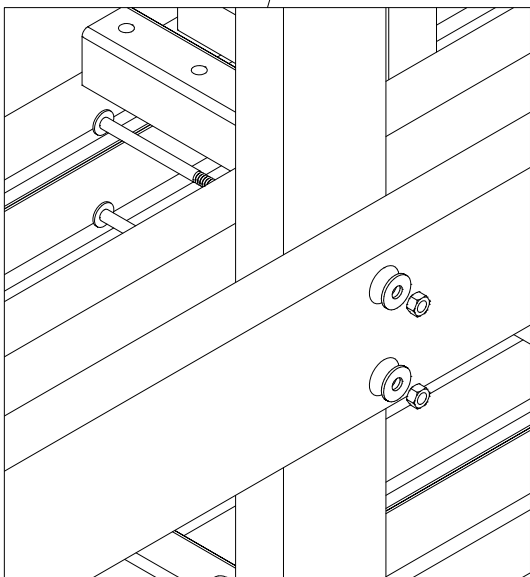
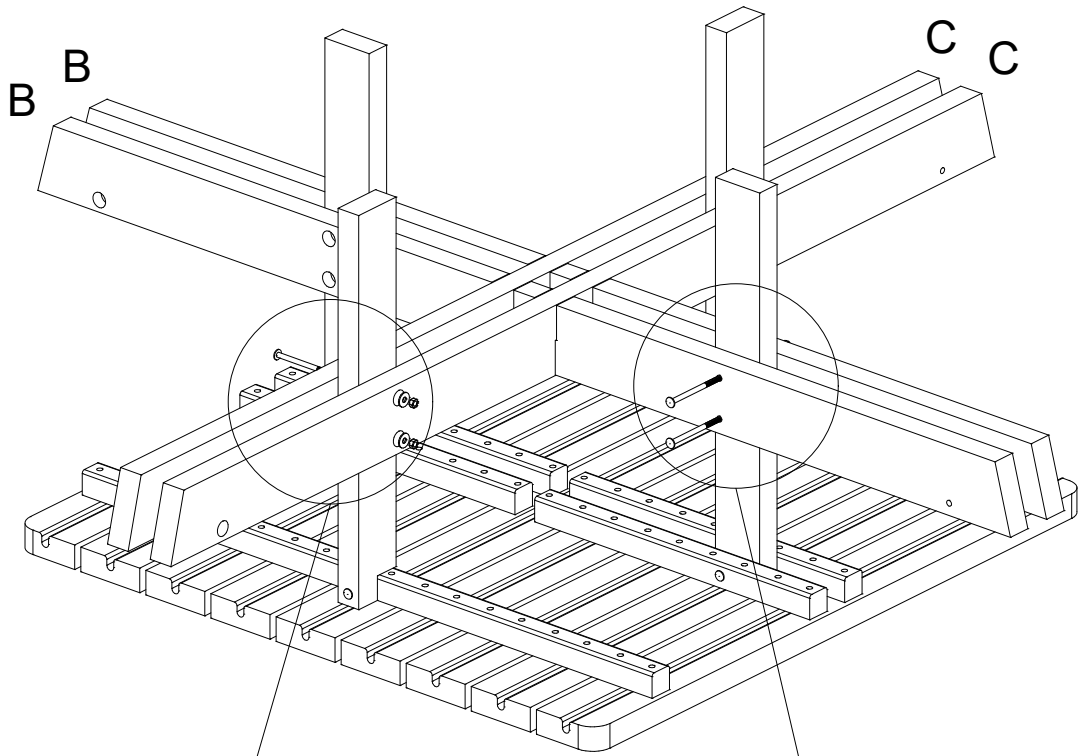
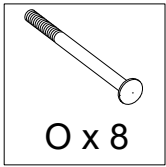
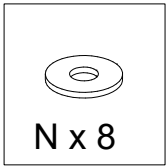
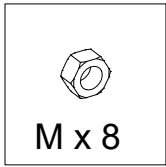

3

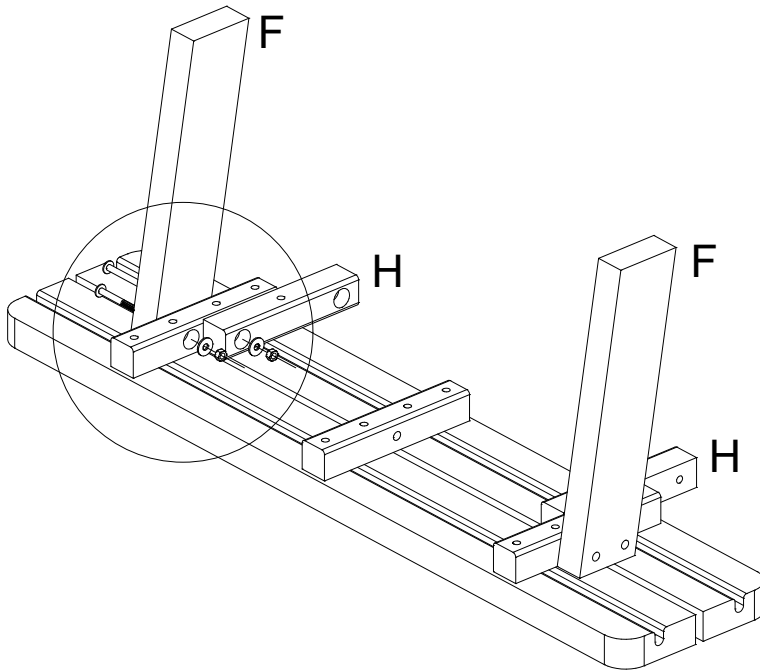

x4

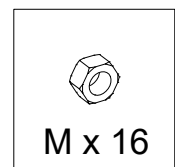
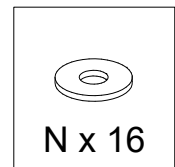
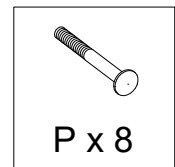
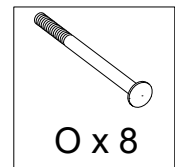
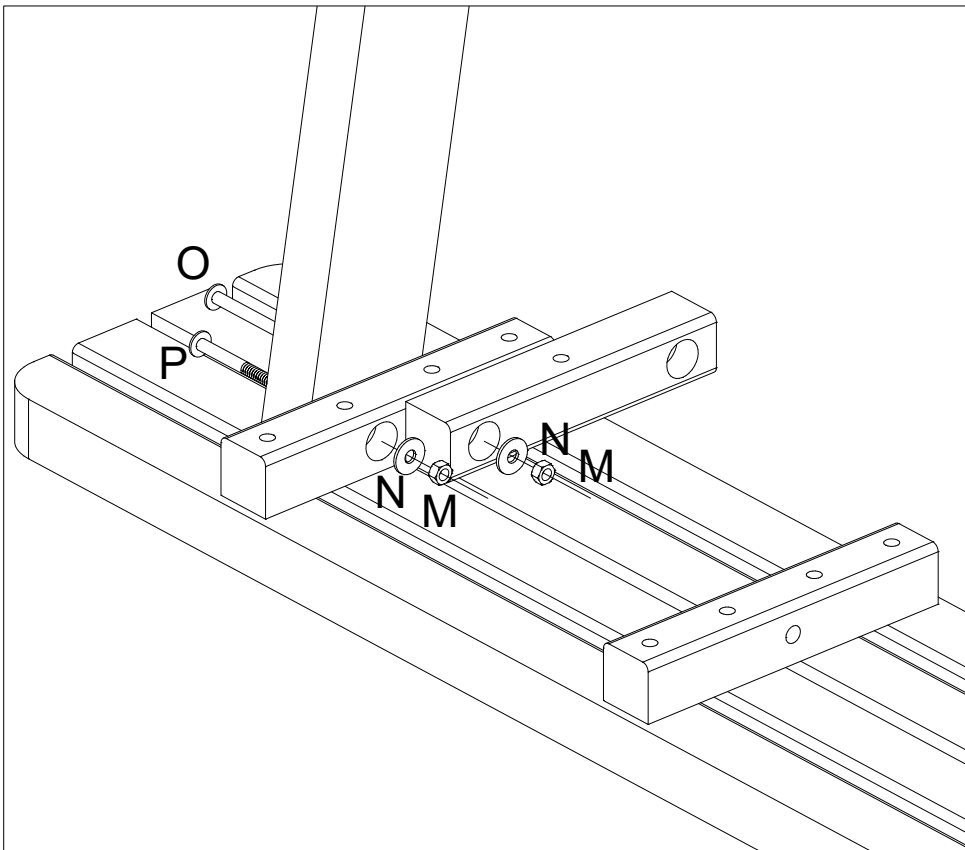

4

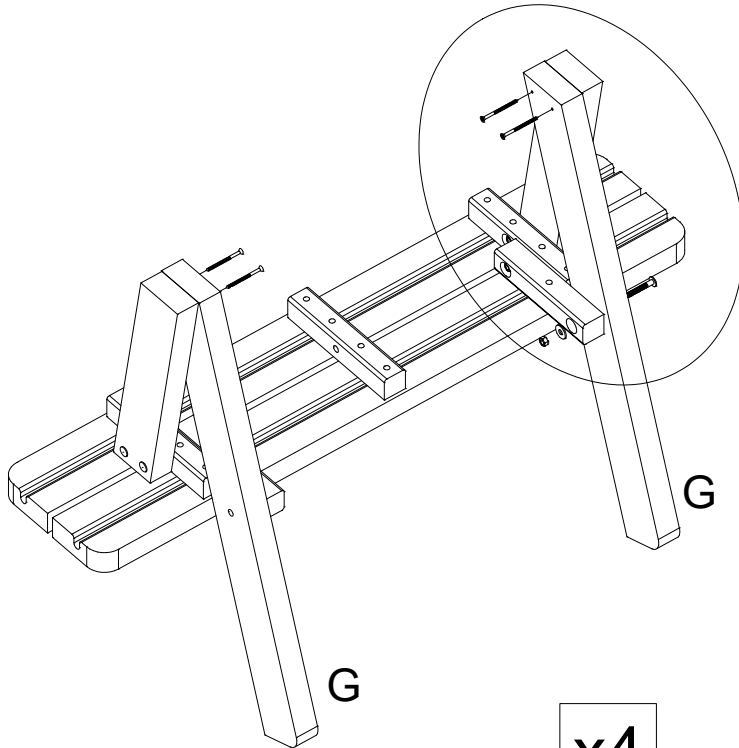

x4

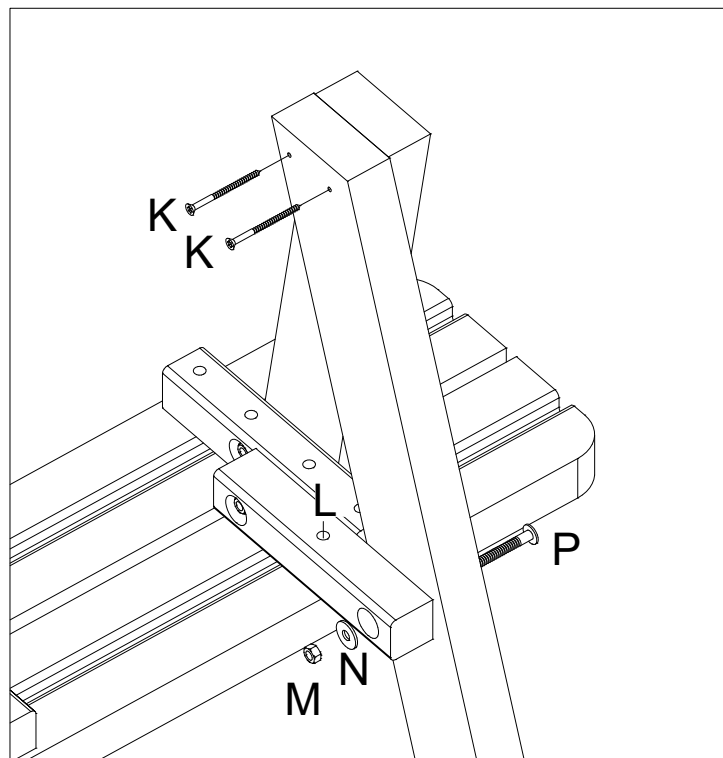
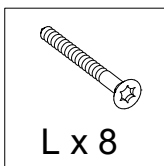
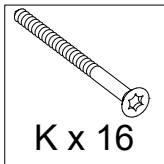
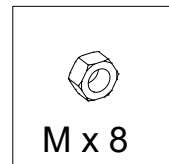
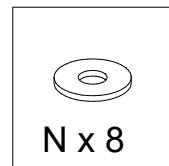
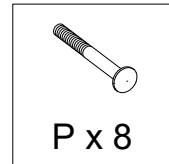

5

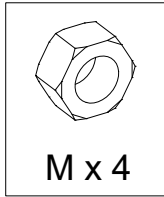
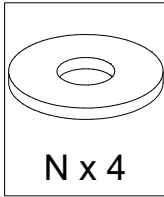
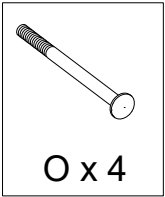
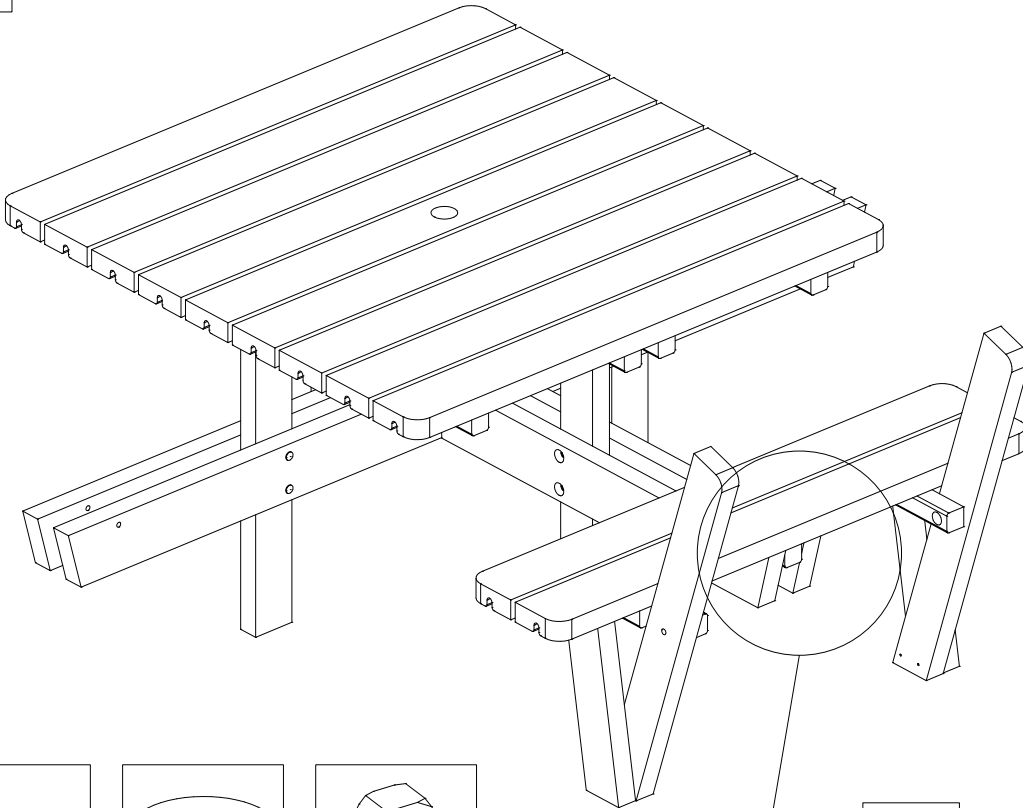

x4

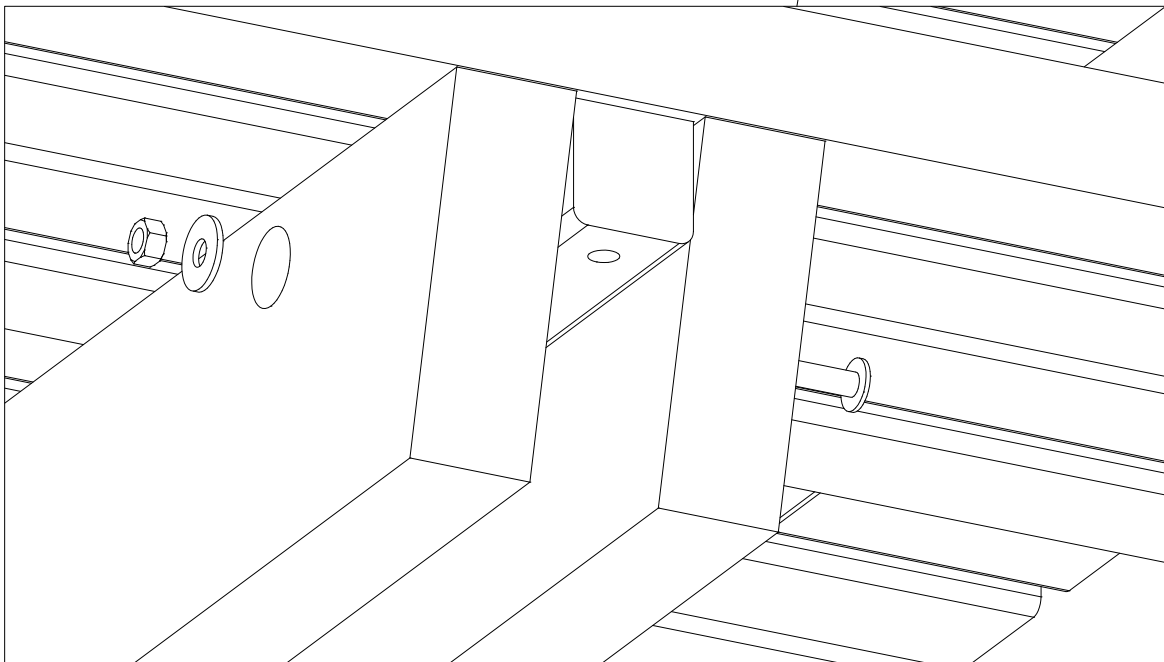

6

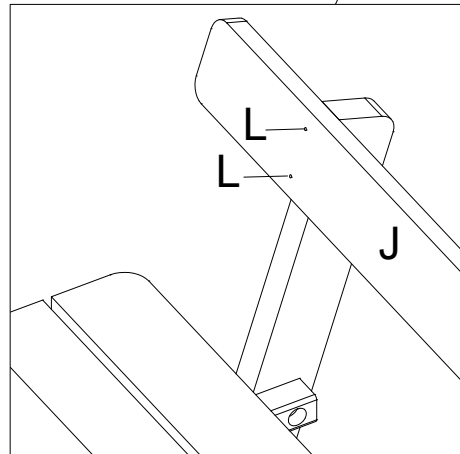
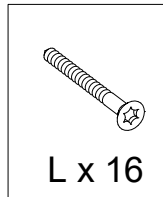
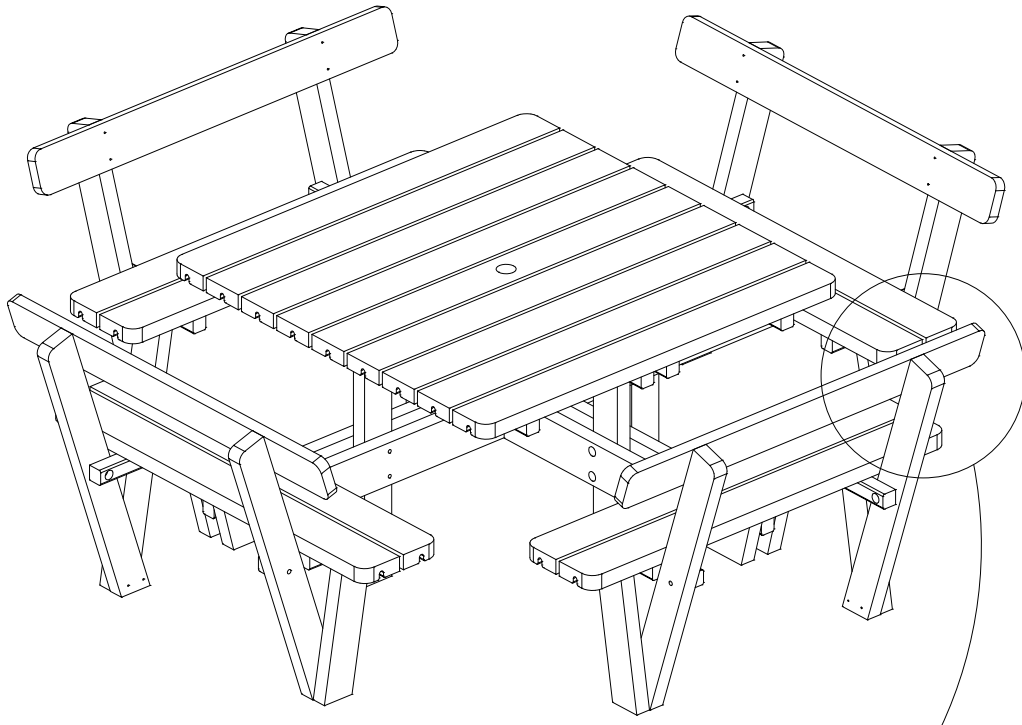

Vedligeholdelse:

Planker er fra fabrikken trykimprægneret, hvorved den traditionelle grønne trykimprægneringsfarve opstår. Pga. fugtindholdet i træet på produktionstidspunktet vil imprægneringen primært blive optaget i overfladen. For at forlænge holdbarheden, er det derfor hensigtsmæssigt at efterbehandle produkterne med træpleje.

Venligst bemærk:

- Egenskaber og karakteristika, der er typiske for træ som:
- Revnedannelse i overfladen. Kan fyldes med en egnet spartelmasse.
 - Harpikslommer/harpiksudtræk
 - Knasthuller er også en naturlig bestanddel i træ.
 - Træ er et naturprodukt

Ovennævnte reducerer ikke træets kvalitet og berettiger derfor ikke til reklamation.

Spørg din lokale farveekspert om efterbehandling.

Gem denne vejledning til senere brug.

Pflegeanleitung:

Die Planken sind werkseitig kesseldruckimprägniert, woher die traditionelle grüne Imprägnierfarbe stammt. Aufgrund des Feuchtigkeitsinhalts im Holz zum Produktionszeitpunkt wird die Imprägnierung hauptsächlich in der Oberfläche aufgenommen. Um die Haltbarkeit zu verlängern, ist es daher angebracht die Produkte mit einem Holzpflegemittel nachzubehandeln.

Bitte beachten:

Folgende Eigenschaften und Charakteristika sind typisch für Holz:

- Rissbildung in der Oberfläche. Kann mit einer geeigneten Spachtelmasse gefüllt werden
- Harztaschen/Harzaustretungen
- Astlöcher können ebenfalls ein natürlicher Bestandteil im Holz sein
- Holz ist ein Naturprodukt

Obenstehendes reduziert nicht die Qualität des Holzes und berechtigt daher nicht zu einer Reklamation.

Fragen Sie Ihren Fachhändler bezüglich der Nachbehandlung.

Bewahren Sie diese Anleitung für einen späteren Gebrauch.

Maintenance:

Wooden planks are factory pressure-treated, so that the traditional green impregnation-colour occurs. Due to the moisture in the wood at the time of production, the impregnation will primarily be obtained in the surface. To extend durability, it is therefore appropriate to treat the product with wood-care products.

Please note:

Features and typical characteristics of wood:

- Cracking of the surface. Fill with a suitable filler.
- Resin pockets / resin extractions
- The cam holes are also a natural part of wood.
- Wood is a natural product

The above mentioned does not reduce the wood quality and therefore does not justify complaints.

Ask your local DIY store for wood-care products.

Save these instructions for later use.

Entretien :

Les planches sont traitées autoclave à l'usine et leur couleur verte d'imprégnation traditionnelle apparaît lors de ce processus. Due à la teneur en humidité du bois au moment de la production, l'imprégnation est principalement absorbée en surface. Pour prolonger la durée de vie, nous vous recommandons donc de post-traiter les produits avec un produit d'entretien pour le bois.

Merci de noter :

Les propriétés et caractéristiques typiques du bois :

- Formation de fissures sur la surface. Peuvent être rebouchées avec un enduit.
- Poches de résine / taches de résine
- Les trous de nœud font également naturellement partie du bois.
- Le bois est un produit naturel

Cela n'affecte en rien la qualité du bois et ne justifie donc pas les réclamations.

Renseignez-vous auprès d'un expert qui saura vous conseiller sur le post-traitement.

Il est conseillé de conserver ces instructions en cas de besoin ultérieur.